

LED TRI-PROOF LIGHT

XP-PL3040

SPECIFICATION FEATURES

- HOUSING:** Silver, slim, and modern 4ft. design with strong anti-corrosion PVC housing. No internal access required.
- LENS:** Frosted Acrylic lens for maximum light uniformity.
- ELECTRICAL:** Long life LED system available in 4000°K (standard), 80 CRI. Universal driver (120V-277V). 5600 lumen output (40W).
- GASKET:** High-density silicon rubber sealing ring protection to prevent light leaks.
- NOTE:** -20°C and 45°C operating temperature.



APPLICATION:
Commercial Settings, Schools, Warehouses, Offices, Medical, Transportation Settings, and more.

MOUNTING:
Surface or Suspended installation (supplied by others) with stainless steel mounting clips.

LABEL:
Fixture is certified to UL standards.



ORDERING INFORMATION

PRODUCT FAMILY

XP-PL3040

DIMENSIONAL DATA

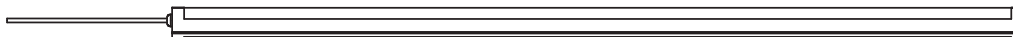
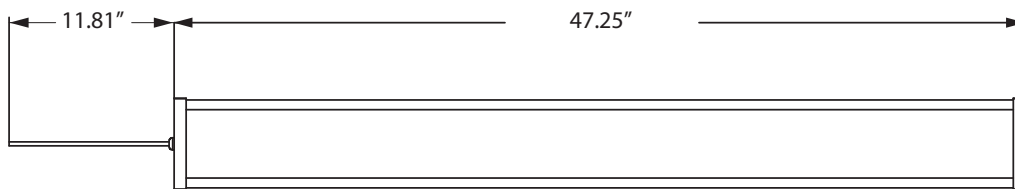
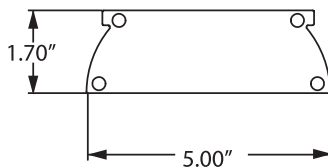

INSTALLATION

SURFACE INSTALLATION

1. Drill 8mm cutting holes, put plastic plug and lock the clips on the ceiling with self-tapping screws.

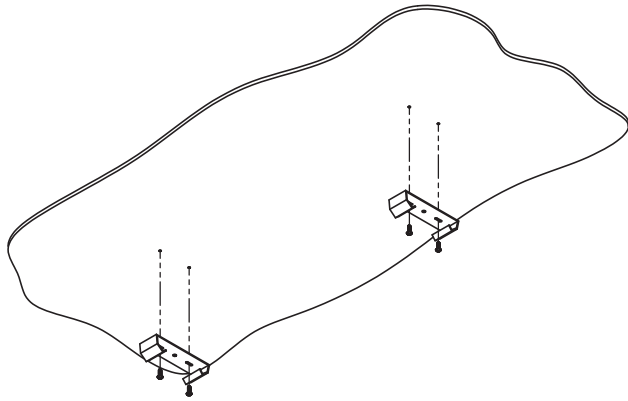

2. Put the lamp into the clips properly.

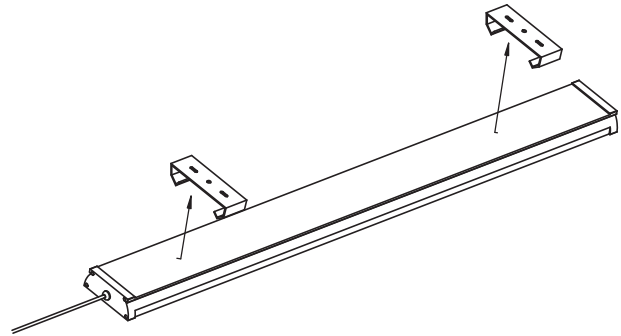

3. Connect to the power.

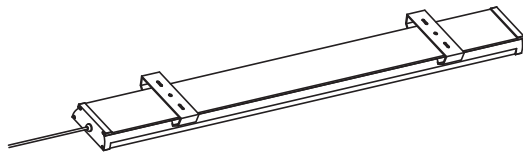

SUSPENDED INSTALLATION

1. Drill 8mm cutting holes, put plastic plug and lock the clips on the ceiling with self-tapping screws (supplied by others).

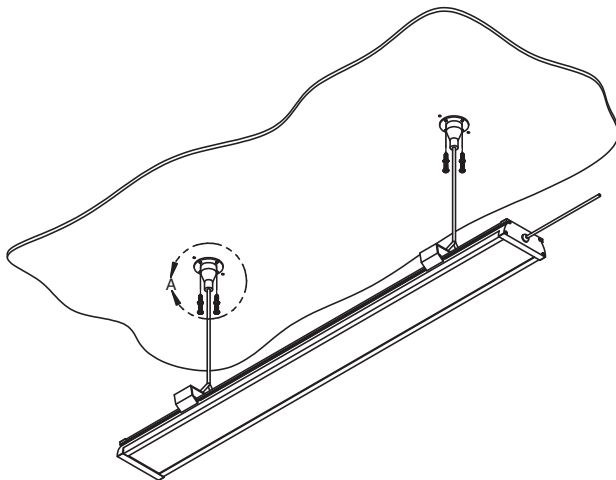

2. Hang the lamp with lifting role (supplied by others) and clip, and then connect to the power.

