

TRIO LED NWTRI

SPECIFICATION FEATURES

- HOUSING:** One-piece marine grade die-cast aluminum.
- LENS:** UV stabilized white opal polycarbonate.
- LED:** Available in three color temperatures 3500°K, 4000°K and 5000°K. 9.6W on 2 LED modules.
- REFLECTOR:** Aluminum reflector to serve as heat sink and unitized with electrical components.
- FASTENERS:** Allen head screws (without center pin) standard.
- FINISH:** Extremely durable oven baked polyester powder coat following a 5 stage iron phosphate pre-treatment in black or white.
- GASKET:** Injection molded, continuous piece silicone rubber gasket to prevent infiltration.



APPLICATION:

VR Architectural Settings, Public Areas, Corridors, Stairways, Underpasses, Parking Garages, Restrooms, Lobbies, Schools, and more.

MOUNTING:

Surface wall installation.

LABEL:

Fixture is certified to UL standards by Intertek Testing Laboratories.



ORDERING INFORMATION

Ex: NWTRI-40-UN-BK

PRODUCT FAMILY	LAMP TYPE	VOLTAGE	FINISH	OPTIONS
NWTRI	35 = 3500°K 40 = 4000°K 50 = 5000°K	12 = 120V 27 = 277V UN = Universal (120V-277V)	BK = Black WH = White BZ = Bronze PA = Painted Aluminum	EML* TH

KEY

EML = Emergency Battery (remote)*
TH = Torx Head Screws (with center pin)

*Cannot use with UN voltage

DIMENSIONAL DATA

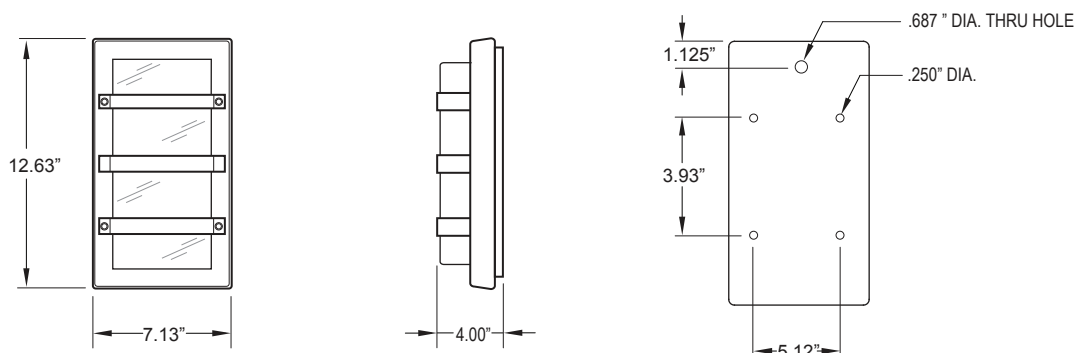

Notes:
Specifications and Dimensions are subject to change without notice. If lamp type is not specified at time of quote or order, fixture will be set with 3500°K. For additional options and dimensional details please consult your New Star Lighting Representative.