

PROJECT: _____
 TYPE: _____
 PRODUCT: _____
 APPROVED BY: _____

PRODUCT FEATURES

- Intended for Modular Cleanrooms, Hospitals, Hi-Tech Manufacturing, Laboratories, Food Processing Facilities, Commercial Kitchens, and more
- 2" Depth accommodates shallow wall plenums and modular rooms
- Single Face - available with red or green lettering
- NSF2 Splash/Non-Food Zone listed. Fixture is certified to UL standards for Wet Locations. IP65 Rated per IEC60598. Meets ISO 3/Class 1 Cleanrooms
- This product is Made in America and complies with the Buy American Act (BAA)



MOD

ORDERING INFORMATION

Example: MOD-HS-OS-RW



MOD				
Series	Housing HP = 20Ga. SS Painted HS = 20Ga. SS Mill Finish	Overlap Frame OP = 18Ga. SS Painted OS = 18Ga. SS Brushed	Lettering RW = Red Letters GW = Green Letters	Options EM = Emergency Battery (remote)

SPECIFICATIONS

HOUSING: 20-Gauge formed stainless steel housing with continuous seam welds.

FRAME: Single face overlapping doorframe in 18-gauge stainless steel.

LENS: .125 Clear polycarbonate lens.

LED: Minimum 50,000 hours with 70% lumen maintenance in a 25°C ambient temperature, compliant with IES LM-80 testing standards.

ELECTRICAL: Long life 7W LED system illuminates red or green legend. Universal voltage (120V-277V).

LEGEND: Legend illuminated by white LEDs with red or green lens. Lettering six inches high with .750" stroke. Chevron arrows are field selectable for the desired direction.

FINISH: White gloss antimicrobial powder coat finish following multi-stage iron phosphate pre-treatment. Brushed stainless steel overlapping frame will be left unpainted if specified.

FASTENERS: Stainless steel Phillips fasteners. Finish to match frame.

GASKET: Closed-cell EPDM and closed-cell silicone gaskets prevent air contaminants from entering the fixture.

INSTALLATION: Recessed installation. Suitable for modular walls.

LABEL: Fixture is certified to UL standards by Intertek Testing Laboratory. IP65 rating per IEC60598. Meets standards for ISO3/Class 1 Cleanrooms. NSF2 Splash/Non-Food Zone. UL924 Rated. This product is Made in America and complies with the Buy American Act (BAA).

WEIGHT: 10 lbs.



New Star Lighting

2225 W Pershing Rd, Chicago, IL 60609
 (773) 847-1400
www.newstarlighting.com

Specifications and dimensions are subject to change without notice. For additional options and dimensional details, please consult your New Star Lighting representative.

© 2024, New Star Lighting. All rights reserved. Unauthorized duplication or distribution is prohibited.

DIMENSIONAL DATA

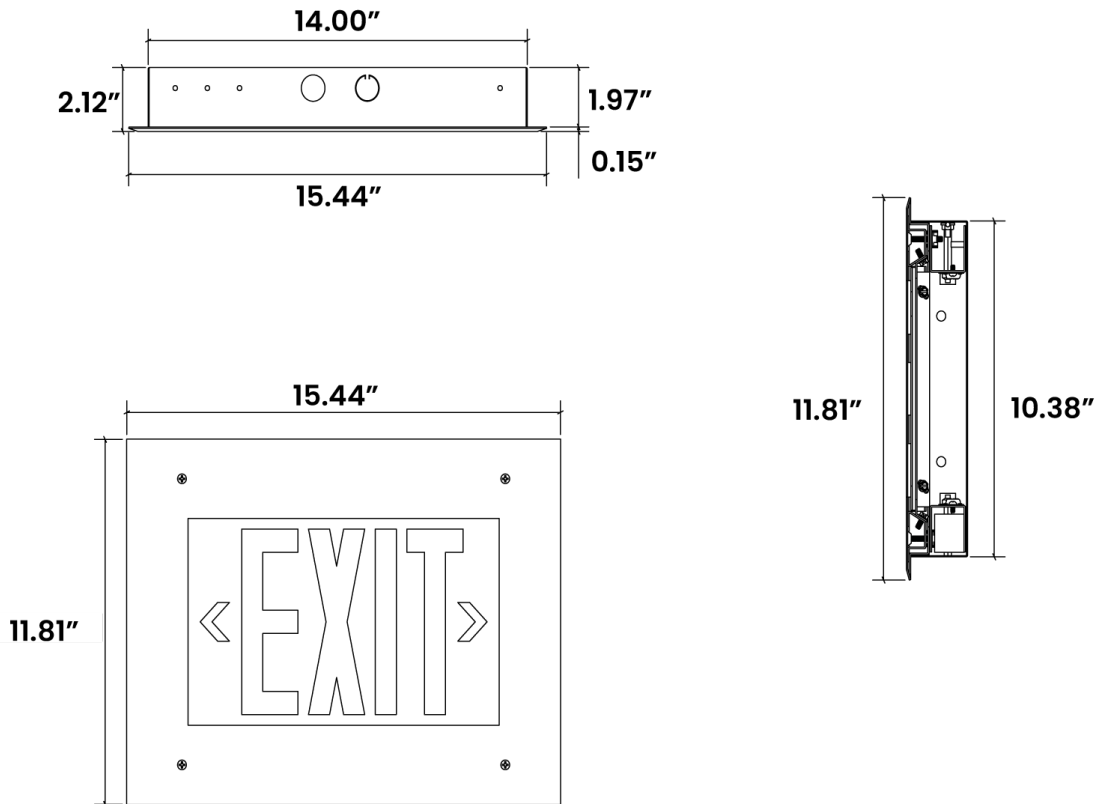

New Star Lighting

2225 W Pershing Rd, Chicago, IL 60609
(773) 847-1400
www.newstarlighting.com

Specifications and dimensions are subject to change without notice. For additional options and dimensional details, please consult your New Star Lighting representative.

© 2024, New Star Lighting. All rights reserved. Unauthorized duplication or distribution is prohibited.