

STARCLEAN SCRH EMERGENCY SERIES

NEMA4X / NSF



PROJECT: _____
 TYPE: _____
 PRODUCT: _____
 APPROVED BY: _____



SCRH Series

PRODUCT FEATURES

- Intended for Food Processing, Industrial, Marine and Coastal applications and more
- Two fully adjustable, ultra bright 3.6 watt high performance MR-16 base LED lamp heads for optimized center-to-center spacing
- Fixture is certified to UL standards for Wet Locations. IP66 rated per IEC60598. NEMA4x rated and NSF Splash/Food Zone listed.

ORDERING INFORMATION

Example: SCRH-1-WH



SCRH			
Series	Heads 1 = Single 2 = Twin	Housing Color WH = White BK = Black	Options TH = Torx® head fasteners* *New Star Promise applies with TH option



New Star Lighting

2225 W Pershing Rd, Chicago, IL 60609
 (773) 847-1400
 www.newstarlighting.com

Specifications and dimensions are subject to change without notice. For additional options and dimensional details, please consult your New Star Lighting representative.

© 2025, New Star Lighting. All rights reserved. Unauthorized duplication or distribution is prohibited.

STARCLEAN SCRH EMERGENCY SERIES

NEMA4X / NSF



SPECIFICATIONS

CONSTRUCTION: Housing is reinforced polycarbonate construction in white or black finish. Corrosion-resistant enclosure with one piece, high-impact resistant UV-stabilized polycarbonate lens and molded gasket with stainless steel fasteners. Knockouts provided for conduit feed applications.

ELECTRICAL: Powered from low voltage 6V/12V DC power source with low voltage wiring (not provided).

FASTENERS: Stainless steel Philips fasteners. Optional tamper-resistant Torx® head fasteners provides New Star Promise warranty.

INSTALLATION: Suitable for wall or ceiling mount.

WARRANTY: Five (5) year warranty on all electronics and housing. Battery prorated for five years. New Star Promise warranty on physical construction when TH option is selected.

LABEL: IP66 rated per IEC60598. NEMA4X rated and NSF Food-Zone/Splash Zone listed. This product meets NFPA 101 Life Safety Code, NEC, OSHA, Local and State Codes.

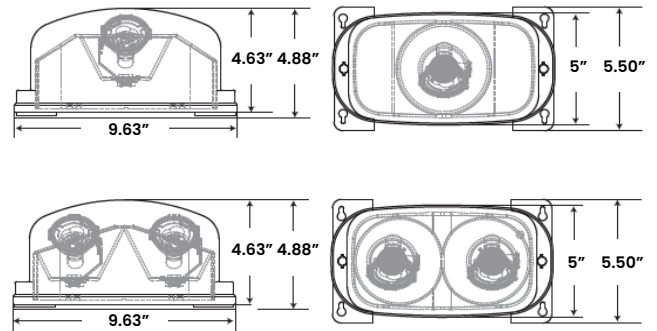

The SCRH Series is covered by our New Star Promise when Torx® head fasteners are selected.

Our promise means we will repair or replace any of our High Abuse or Vandal-Resistant architectural luminaires when installed according to our instructions for the life of the original installation if the fixture should fail due to physical abuse*.

*Damage caused by gunfire and chemical reactions is not covered by the New Star Promise.

DIMENSIONAL DATA

 **New Star Lighting**
2225 W Pershing Rd, Chicago, IL 60609
(773) 847-1400
www.newstarlighting.com

Specifications and dimensions are subject to change without notice. For additional options and dimensional details, please consult your New Star Lighting representative.

© 2025, New Star Lighting. All rights reserved. Unauthorized duplication or distribution is prohibited.